

FOR STUDENTS WHO HAVE COMPLETED ALGEBRA 1

(Students entering Geometry)

Name: _____
Date: _____ Period: _____

Dear Parent/Guardian and Student,

Attached you will find a review packet of skills which each student is expected to know upon the start of the year. Students will be given a test (no calculators) on this information during the second week of the school year. Teachers will go over the answers from the packet during the first week of school and minimal direct instruction will be given on these concepts, as they are a review from Algebra 1. Students may seek additional help during RECAP to ask questions.

Topics from Algebra 1 to be tested during the second week of school.

Real Numbers and Operations
Algebraic Expressions and Models
Solving Linear Equations
Rewriting Equations and Formulas
Solving Linear Inequalities
Solving Absolute Value Equations and Inequalities

Functions and Their Graphs
Slope and Rate of Change
Quick Graphs of Linear Equations
Writing Equations of Lines
Correlation and Best Fitting Lines
Linear Inequalities in Two Variables

Solving Linear Systems by Graphing
Solving Linear Systems Algebraically (Substitution and Linear Combinations)
Graphing and Solving Systems of Linear Inequalities

Adding, Subtracting, Multiplying Polynomials
Factoring

You may also access the following websites to assist your child.

www.purplemath.com, www.math.com, www.khanacademy.com

It is recommended that students who score between 80 and 100 continue with the current course. Students who score below an 80 may consider retaking Algebra 1, as it is imperative for future successes in math to have essential, baseline skills.

Have a good summer.

The PAMS Math Department

1. Real Numbers and Operations

Whole: 0, 1, 2, ...

Integers: ..., -2, -1, 0, 1, 2...

Rational: Can be written as a fraction or a repeating or terminating decimal.

Irrational: Cannot be written as a fraction or a repeating or terminating decimal.

Properties of Addition and Multiplication

1. Commutative Property: $a + b = b + a$
2. Associative Property: $(a + b) + c = a + (b + c)$
3. Identity Property: $a + 0 = a$ for addition, $a \bullet 1 = a$ for multiplication
4. Inverse Property: $a + (-a) = 0$ for addition, $a \bullet \frac{1}{a} = 1$
5. Distributive Property: $a(b + c) = ab + ac$

Practice Set 1 - Identify the following numbers as either W, In, R, or Irr. Remember, the numbers could fall into more than one category!

1. 4.5 2. -17 3. $\frac{2}{3}$ 4. $\sqrt{15}$ 5. $\sqrt{16}$

6. Plot the following values on a number line. $-\frac{4}{3}, \sqrt{2}, 2.7, \pi, -1.2$



- 7.
- a. What is the sum of -9 and 16?
 - b. What property is represented here: $4 + (1+5) = (4+1) + 5$
 - c. What property is represented here: $8 = 8 \bullet 1$
 - d. True or False: $(a - b) = (b - a)$

2. Algebraic Expressions and Models

Order of Operations

Parentheses
Exponents
Multiplication } From left to right!
Division }
Addition } From left to right!
Subtraction }

Vocabulary

Terms: Parts added together to make the expression.

Coefficients: The number located in front of the variable.

Constant: Numbers in an expression without a variable.

Practice Set 2

- Simplify the following:
 - 3^4
 - $(-3)^4$
 - $-(3)^4$
- Simplify:
 - $\frac{-4 + 2(-2 + 5)^2}{5 - (2 - 4)^3}$
 - $-3x^2 - 5x + 7$, when $x = -2$
 - $6^2 \div 4 \bullet 3 - (8 - 5) + 2^3$
- Identify the following components from the following expression. $5x^7 - 8x + 47$
 - The number of terms
 - Leading coefficient
 - Constant Term
- Simplify:
 - $3x^2 - x + 7 - x^2$
 - $2(x + 1) - 3(2x - 4)$
 - $4(x^2 - 2) - 2(3 - 5x^2)$

3. Solving Linear Equations

Practice Set 3:

1. Solve the following equations.

a. $\frac{3}{7}x + 9 = 15$

b. $5n + 11 = 7n - 9$

c. $4(3x - 5) = -6\left(-\frac{5}{3}x + 8\right) - 6x$

d. $\frac{1}{3}x + \frac{1}{4} = x - \frac{1}{6}$

4. Rewriting Equations and Formulas

Practice Set 4:

1. Solve the following equation for y . $7x - 3y = 8$

2. Solve the Fahrenheit equation for Celsius. $F = \frac{9}{5}C + 32$

6. Solving Absolute Value Equations and Inequalities

*The absolute value of a number x , is written $|x|$, is the distance the value is from zero.

The absolute value of a number is always positive. $|x| = 5$ or -5

Example 1: Solve: $|2x-5|=9 \longrightarrow \begin{array}{l} 2x-5=9 \text{ or } 2x-5=-9 \\ x=7 \quad \text{or} \quad x=-2 \end{array}$

*To solve an absolute value inequality, it is important to remember that a $<$ or \leq represents an **and** statement and a $>$ or \geq represents an **or** statement.

Example 2:
$$\begin{array}{l} |2x+7| < 11 \\ -11 < 2x+7 < 11 \\ -18 < 2x < 4 \\ -9 < x < 2 \end{array}$$

Example 3:
$$\begin{array}{l} |3x-2| \geq 8 \\ 3x-2 \leq -8 \quad \text{or} \quad 3x-2 \geq 8 \\ x \leq -2 \quad \text{or} \quad x \geq \frac{10}{3} \end{array}$$

Practice Set 6:

Directions: Solve the following absolute value equations.

1. $|6x-3|=15$

2. $|4x+7|-11=-2$

Directions: Solve and graph the following absolute value inequalities.

3. $|4x+10| < 20$

4. $|x-16| \geq 24$



7. Finding Slope

Finding Slope from Graph

$$m = \frac{y_2 - y_1}{x_2 - x_1} = \frac{\text{rise}}{\text{run}} = \frac{1}{2}$$

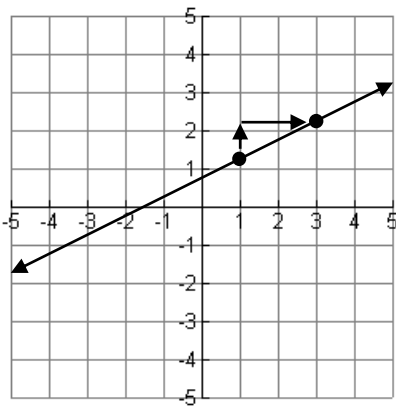

Finding Slope from Two Points

$$m = \frac{y_2 - y_1}{x_2 - x_1} = \frac{\text{rise}}{\text{run}}$$

Example: Find the slope of the line that crosses (-2, 7) and (3, -1)

$$\frac{-1 - 7}{3 - (-2)} = \frac{-8}{5}$$

Practice Set 7:

Directions: Find the slope of the following lines.

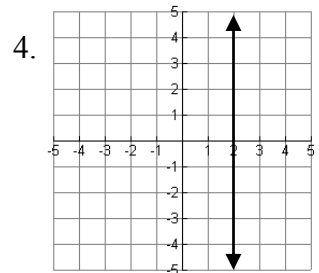
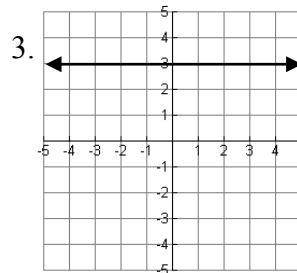
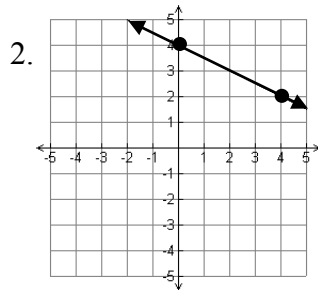
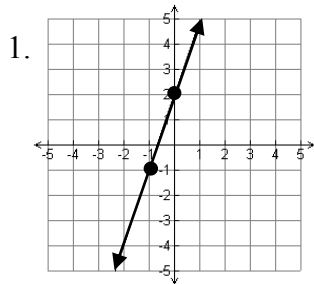

5. (8, 10), (-7, 14)

6. (-19, 6), (15, 16)

8. Graphing Linear Equations

Slope-Intercept Form

Graph $y = \frac{2}{3}x - 4$

*The y-intercept is -4.

*The slope is $\frac{2}{3}$.

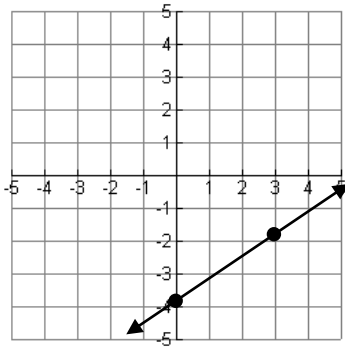

Standard Form

Graph $-2x + y = -2$

*Use x and y intercepts.

* $x = 0$ for y intercept and $y = 0$ for x intercept

$$-2x + 0 = -2$$

$$x = 1$$

$$-2(0) + y = -2$$

$$y = -2$$

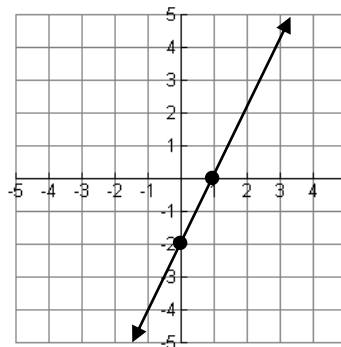

Practice Set 8:

Directions: Graph the following equations.

1. $y = 3x - 1$

m =

b =

2. $y = \frac{-2}{3}x + 2$

m =

b =

3. $-2x + 3y = -6$

x - int.

y - int.

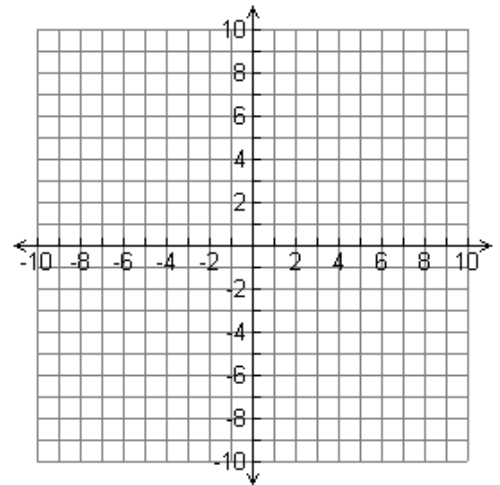
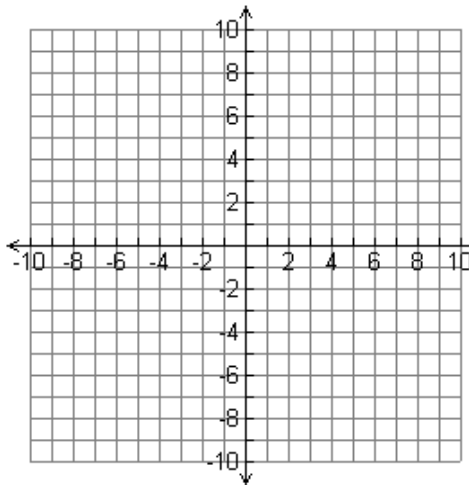
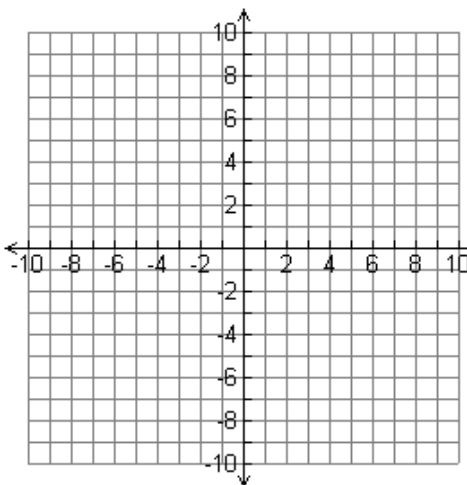

9. Graphing Linear Inequalities

1. Graph the line the same way you would any other linear equation.
2. Remember, $<$ or $>$ represents a dashed line and \leq or \geq represents a solid line.
3. Chose a test point on the graph to see if it satisfies the inequality. If it does, shade to cover the test point as it is a solution. If it does not work, shade away from it.

Example: Graph $y < -\frac{1}{4}x + 3$

Test Point: $(0, 0)$

$$0 < \frac{1}{4}(0) + 3$$

$$0 < 3$$

TRUE, so shade toward $(0, 0)$

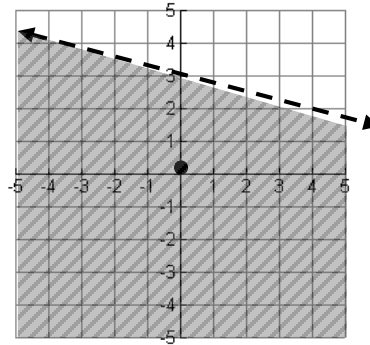

Practice Set 9:

Directions: Graph the following inequalities.

1. $y > -2x - 3$

2. $-3y \geq -12x - 6$

3. $4y + 3 < 4$

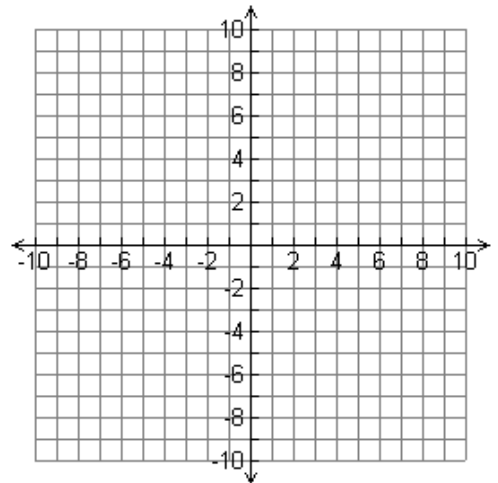
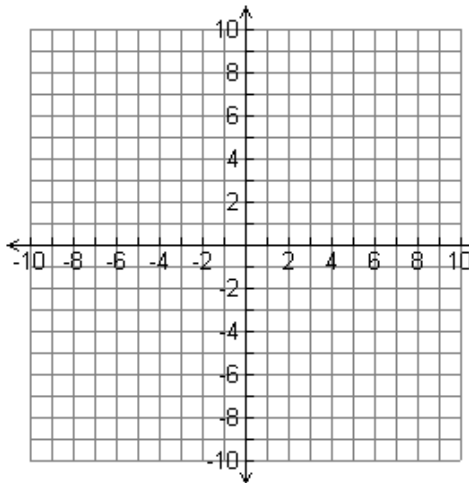
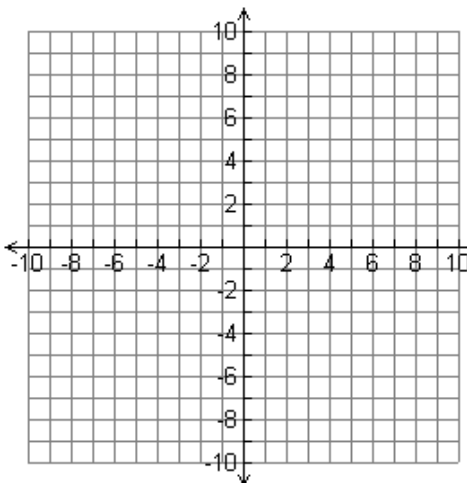

10. Writing Linear Equations in Slope-Intercept Form

<p><u>Slope-intercept form:</u> $y = mx + b$</p> <p>1) Find the slope of the line. $m = \frac{-9-5}{1-(-4)} = \frac{-14}{5}$</p> <p>2) Find the y-intercept. $-9 = \frac{-14}{5}(1) + b$ $-9 = \frac{-14}{5} + b$ $-9 - \left(\frac{-14}{5}\right) = \frac{-14}{5} - \left(\frac{-14}{5}\right)$ $\frac{-31}{5} = b$</p> <p>3) Write an equation of the line. $y = \frac{-14}{5}x + \frac{-31}{5}$</p>	<p><u>Important!</u></p> <p>*1. Two lines are parallel if they have the same slope.</p> <p>*2. Two lines are perpendicular if they have opposite reciprocal slopes.</p>
--------------------------------------------------------------------------------------------------------------------------------------------------------------------------------------------------------------------------------------------------------------------------------------------------------------------------------------------------------------------------------------------------------------------------------------------------------------------------------------------------------------	--------------------------------------------------------------------------------------------------------------------------------------------------------------------------------

Practice Set 10: Directions: Write the equation of the line in slope-intercept form.

1. $(2, -1)$, $m = 3$	2. $(3, 4)$, $m = \frac{1}{2}$
3. Write the equation of the line that is parallel to $y = 4x - 5$ and passes through $(-3, 10)$.	4. Write the equation of the line perpendicular to $y = \frac{1}{4}x + 7$ and passes through $(2, -9)$.
5. Passes through $(-4, -1)$, $(-9, 2)$	6. Passes through $(-17, -8)$, $(-7, -4)$

11. Writing Linear Equations in Point-Slope Form

<u>Point-slope form:</u>	<u>Example 1:</u>	<u>Example 2:</u>
$y - y_1 = m(x - x_1)$	$m = \frac{3}{4}, (-5, 4)$	$(-4, 1)$ and $(5, -3)$
1. Find the slope of the line.	$m = \frac{3}{4}$	$m = \frac{-3-1}{5-(-4)} = \frac{-4}{9}$
2. Substitute m , x_1 , and y_1	$y - 4 = \frac{3}{4}(x + 5)$	$y - 1 = \frac{-4}{9}(x + 4)$ OR $y + 3 = \frac{-4}{9}(x - 5)$

Practice Set 11: Directions: Write the equation in point-slope form.

1. $(2, -1), m = 3$	2. $(3, 4), m = \frac{1}{2}$
3. $(5, 12), (6, -2)$	4. $(-4, -1), (-9, 2)$

12. Writing Linear Equations in Standard Form

<u>Standard Form:</u> $Ax + By = C$	<u>Example 1:</u>	<u>Example 2:</u>
1. Isolate the variable terms on the left and the constant term on the right.	$y = \frac{2}{5}x - 3$ $-\frac{2}{5}x + y = -3$	$(2, -2), (3, -4)$ $m = \frac{-4 - (-2)}{3 - 2} = \frac{-2}{1}$
3. Multiply each side by -5 to have integer coefficients and A to be positive.	$-5\left(-\frac{2}{5}x + y\right) = -5(-3)$ $2x - 5y = 15$	$y - 3 = -2(x + 4)$ $y - 3 = -2x - 8$ $2x + y = -5$

Practice Set 12: Directions: Write the equation in standard form with integer coefficients.

1. $4x - y - 7 = 0$	2. $y = -\frac{3}{4}x + \frac{5}{2}$
3. $3x + 9 = \frac{7}{2}y$	4. $(2, 9), m = -7$

13. Writing an Equation for Line of Best Fit

Approximate the best fitting line for the data.

1) Graph the table

Hours Studying	1	1	2	3	3	4	6	5	7
% Increase	2	-1	2	1	5	4	1	7	6

2) Sketch a line that best fits the data.

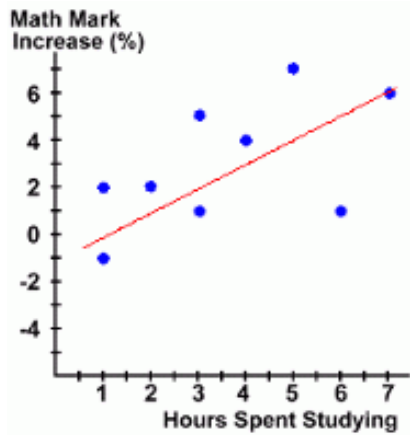

3) Estimate the coordinates of two points on the line, **not necessarily data points.

(7, 6) and (3, 2)

$$m = \frac{2-6}{3-7} = \frac{-4}{-4} = 1$$

$$y - 2 = 1(x - 3)$$

$$y - 2 = x - 3$$

$$y = x - 1$$

* Positive correlation.

Practice Set 13: Directions: Draw a scatter plot of the data, approximate a best-fit line, and state the correlation.

1.	(0)	(1)	(2)	(3)	(4)	(5)	(6)	(7)	(8)
Year, t	1980	1981	1982	1983	1984	1985	1986	1987	1988
Pounds, b	1.6	1.8	2.2	2.3	2.7	2.9	3.5	3.6	4.2

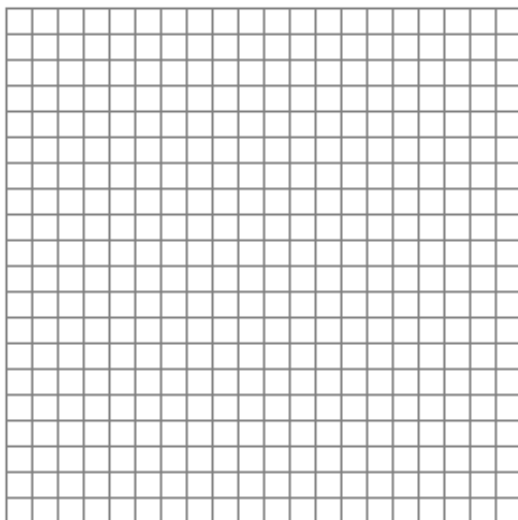

***Use $t = 0$ to represent 1980

2.

Years Since 1990	0	1	2	3	4	5	6
Home Runs	51	44	43	46	40	50	52

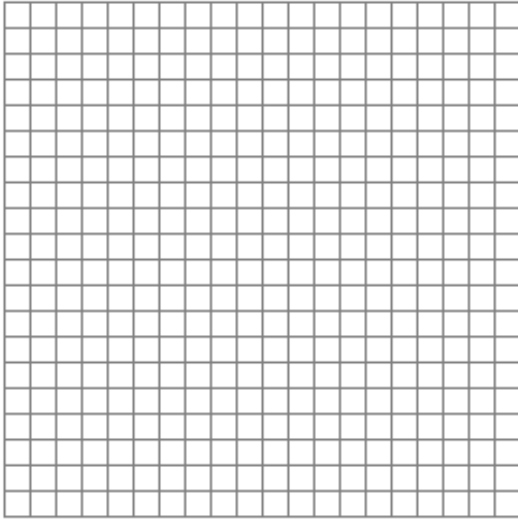

14. Solving Linear Systems by Graphing

Graphing:

- Graph both equations. (ie: slope-intercept form, x- and y-intercepts, table of values)
- Find the point of intersection.

$$y = x + 3$$

$$y = -\frac{1}{2}x$$

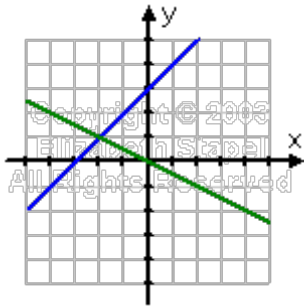

The solution is $(-2, 1)$.

$$-x + y = 3$$

$$-x + y = -2$$

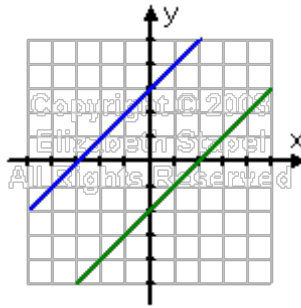

The system has no solution.

$$-x + y = 3$$

$$2x - 2y = -6$$

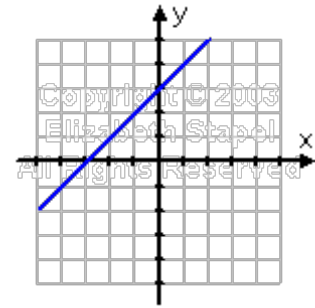

The system has infinitely many solutions.

Practice Set 14: Directions: Solve the following systems of equations by graphing.

- $$y = -x + 2$$

$$y = x - 4$$

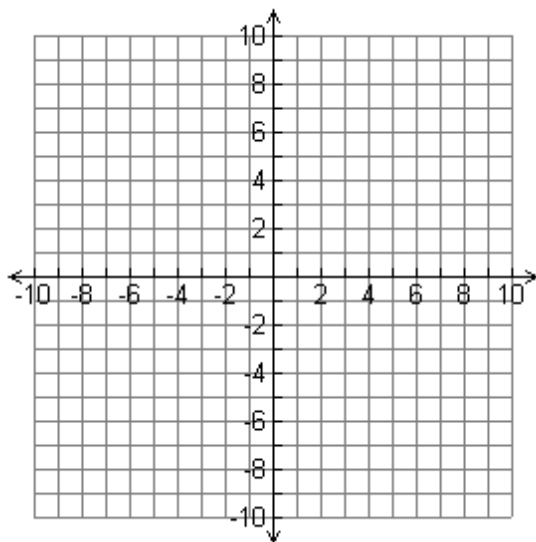

Solution: _____

- $$x + y = -2$$

$$2x - 3y = -9$$

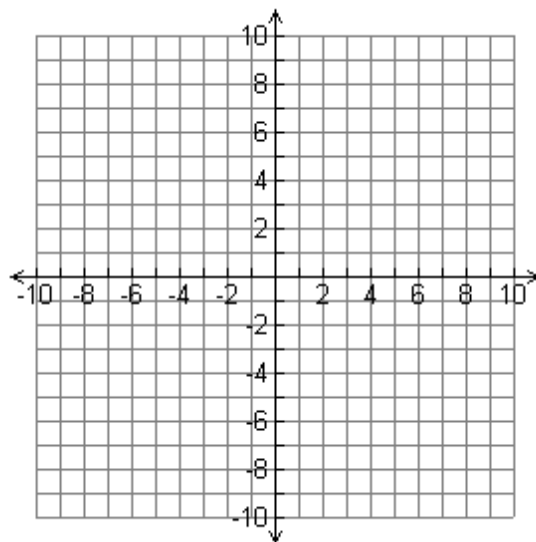

Solution: _____

3. $y = 5x - 2$
 $2y + 4 = 10x$

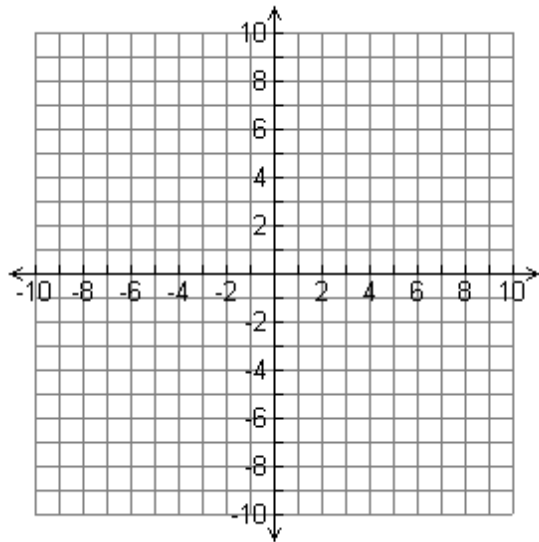

Solution: _____

4. $y = -\frac{1}{2}x + 4$
 $2y + x = 2$

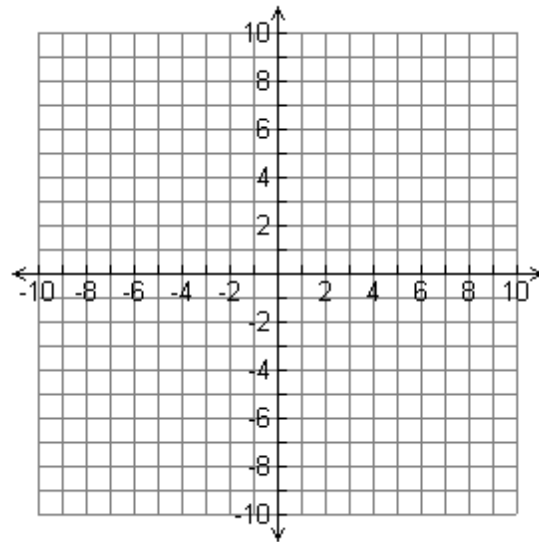

Solution: _____

15. Solving Linear Systems using Substitution

Substitution:

1) Solve one of the equations for one of its variables.

$$3x + 4y = -4$$

$$x + 2y = 2 \quad \rightarrow \quad x = -2y + 2$$

2) Substitute the expression into the other equation and solve for the other variable.

$$3(-2y + 2) + 4y = -4$$

$$-6y + 6 + 4y = -4$$

$$-2y + 6 = -4$$

$$-2y = -10$$

$$y = 5$$

3) Substitute the value into any equation from step 1 to solve for the other variable.

$$x = -2y + 2$$

$$x = -2(5) + 2$$

$$x = -8$$

$$(-8, 5)$$

4) Write you answer as an ordered pair.

Problem Set 15: Directions: Solve the system using substitution.

1. $2x - 5y = 9$ $-3x + y = -7$	2. $6x + 2y = 1$ $4x + y = 6$
3. $x - 2y = -1$ $5x - 10y = 4$	4. $6x + 3y = -9$ $2x + y = -3$

16. Solving Linear Systems using Linear Combinations (Elimination)

Linear Combinations:

1) Arrange all equations with like terms in columns.

2) Multiply one or both of the equations by a constant to obtain the same coefficients that differ in sign.

3) Add the revised equations.

4) Substitute the value into the equation from step 1.

5) Write your answer as an ordered pair.

$$2x + 6y = 4 \rightarrow 3(2x + 6y = 4)$$

$$3x - 7y = 6 \rightarrow -2(3x - 7y = 6)$$

$$6x + 18y = 12 \quad 2x + 6y = 4$$

$$-6x + 14y = -12 \quad 2x + 6(0) = 4$$

$$32y = 0 \quad 2x = 4$$

$$y = 0 \quad x = 2$$

(2, 0)

Problem Set 16: Directions: Solve the system using linear combinations.

1. $2x - 3y = 4$
 $16x + 6y = 2$

2. $x - 2y = -1$
 $5x - 10y = -5$

3. $-2x + 3y = 8$
 $x - 5y = -4$

4. $3x - 9y = 3$
 $-x + 3y = 13$

17. Solving Linear Inequalities by Graphing

Graphing:

- 1) Graph both inequalities. (ie: slope-intercept form, x- and y-intercepts, etc)
- 2) Use a test point to determine which way to shade (solutions to the inequality).
- 3) Shade the areas that are satisfied by the inequalities and find the region shaded by both inequalities.

$$2x - 3y \leq 12$$

$$y \leq -\frac{1}{5}x + 4$$

$$x > 0$$

Test Point for first inequality only.

*Use the test point (0, 0) as line
does not cross this point.

(0, 0) creates a TRUE
statement so I will shade
to cover (0, 0) as it is a
solution to the first
inequality.

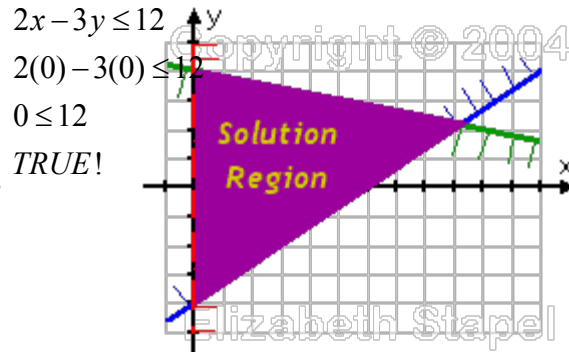
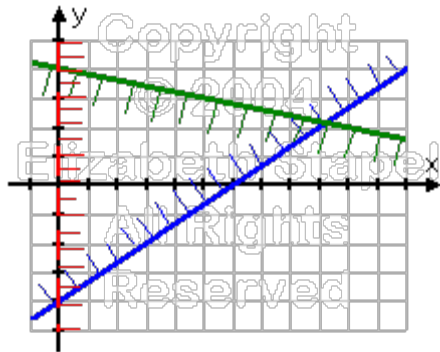

Problem Set 17: Directions: Solve the system of linear inequalities by graphing.

1. $x + 2y > 4$
 $x - 3y < 1$

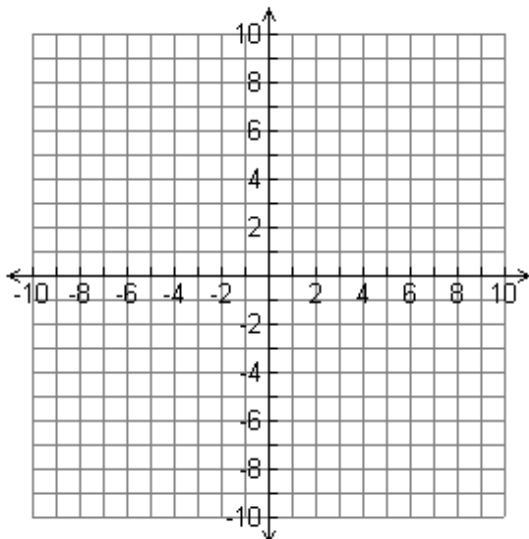

2. $y \leq 5$
 $x \geq 3$
 $y \leq -2$

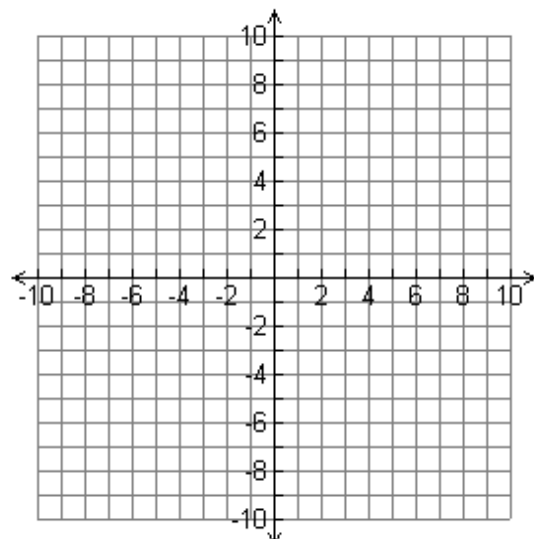

3. $x \geq -3$
 $x \leq 4$
 $y < x + 5$

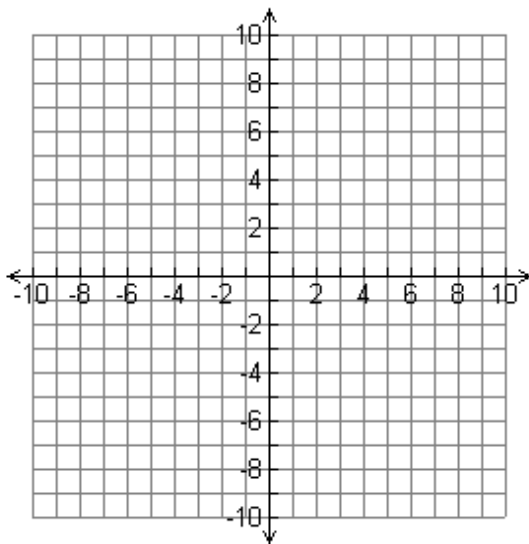

4. $y > \frac{1}{2}x - 4$
 $y \leq -x + 3$
 $y \leq 2x$

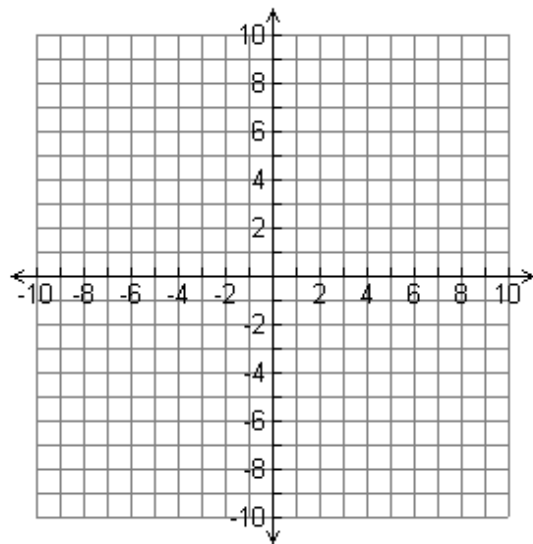

18. Writing and Solving Real World Systems

Writing a System of Equations

- 1) Define your unknowns.
- 2) Create a system to represent the problem.
- 3) Solve the system using the method of your choice.

Example: Rex wants to sign up with a new internet provider.

Internet Provider	Monthly Membership	Hourly Use Fee
Inter-Speedway	\$85	\$0.85
Cyber-Zone	\$60	\$1.35

- Write a system of equations to represent this situation.

$$x = \# \text{ hours} \quad y = \text{total cost} \quad y = .85x + 85$$

$$y = 1.35x + 60$$

- After how many hours will the cost of the different companies be the same? Use mathematics to explain your answer. Use words, symbols, or both to support your explanation.

Use substitution to solve:

$$\begin{array}{rclcl} y = .85x + 85 & & .85x + 85 = 1.35x + 60 & & y = .85x + 85 \\ y = 1.35x + 60 & & -.5x = -25 & & y = .85(50) + 85 \\ & & x = 50 & & y = 42.5 \end{array}$$

After 50 hours, the cost at each company will be \$42.50.

Problem Set 18: Directions: Create a system to represent each real world scenario. Then, solve using the method of your choice.

1. A piggy bank contains a total of 84 coins in nickels and quarters worth \$12.80. How many quarters and nickels are in the piggy bank?

2. The Williams family is going to the Johnstown Summer Carnival. They have two ticket options as shown in the table.

Ticket Option	Admission Price	Price per Ride
A	\$5	\$0.30
B	\$3	\$0.80

How many rides will the Williams have to ride in order for the cost of ticket option A to be the same as the cost for ticket option B? What will the cost be at that time?

19. Polynomials

1. Multiply Polynomials

Use the distributive property to multiply.

$$\begin{aligned} \text{Ex. } (5x)(9x^2 - 8) \\ 45x^3 - 40x \end{aligned}$$

$$\begin{aligned} \text{Ex. } (2x - 4)(-9x + 3) \quad \text{***You can FOIL!!!} \\ -18x^2 + 6x + 36x - 12 \\ -18x^2 + 42x - 12 \end{aligned}$$

2. Factoring

Factor each polynomial.

$$\begin{aligned} \text{Ex. } (6x^3 - 18x^2 - 54x) \\ 6x(x^2 - 3x - 9) \end{aligned}$$

$$\begin{aligned} \text{Ex. } -4a^2b - 8ab^2 + 2ab \\ 2ab(-2a - 4b + 1) \end{aligned}$$

3. Factoring using ac method (when $a = 1$).

$$\text{Ex. Factor } x^2 + 9x - 36$$

1. Multiply the a and c terms.

$$a \cdot c = 1 \cdot (-36) = -36$$

2. Determine what two values multiply to the ac term but add to the b term.

$$\begin{aligned} 12 \cdot (-3) &= -36 \\ 12 + (-3) &= 9 \end{aligned}$$

3. Rewrite your middle term with these two numbers, split the new polynomial and factor.

$$\begin{aligned} x^2 + 9x - 36 \\ x^2 + 12x - 9x - 36 \\ x^2 + 12x \quad - 9x - 36 \\ x(x + 12) - 9(x + 12) \\ (x + 12)(x - 9) \end{aligned}$$

4. Solving using ac method (when $a \neq 1$).

$$\text{Ex. Solve } 3x^2 - 17x + 10 = 0$$

1. Multiply the a and c terms.

$$a \cdot c = 3 \cdot (10) = 30$$

2. Determine what two values multiply to the ac term but add to the b term.

$$\begin{aligned} -2 \cdot (-15) &= 30 \\ -2 + (-15) &= -17 \end{aligned}$$

3. Rewrite your middle term with these two numbers, split the new polynomial and factor.

$$\begin{aligned} 3x^2 - 17x + 10 &= 0 \\ 3x^2 - 2x - 15x + 10 &= 0 \\ 3x^2 - 2x \quad - 15x + 10 &= 0 \\ x(3x - 2) - 5(3x - 2) &= 0 \\ (x - 5)(3x - 2) &= 0 \end{aligned}$$

4. Solve for your solutions.

$$\begin{aligned} x - 5 &= 0 & 3x - 2 &= 0 \\ x &= 5 & x &= \frac{2}{3} \\ x &= 5, \frac{2}{3} \end{aligned}$$

Problem Set 19: Use the directions to complete each problem.

Multiply.

1. $4y(6y^4 - 2y + 5)$

2. $(3x + 4)(-5x + 9)$

3. $(2x + 5)(5x^2 - x - 3)$

Factor.

4. $x^2 + 15x + 44$

5. $x^2 - x - 42$

6. $x^2 - 30x + 56$

Solve.

7. $2x^2 + 9x - 18 = 0$

8. $4x^2 - 13x + 10 = 0$

9. $4x^2 + 17x = -15$ (*HINT*: Set problem equal to zero before beginning!)

ANSWER KEY for Summer Math Packet – Students Who Have Completed Algebra 1

Practice Set 1

1. R 2. In, R 3. R 4. Irr 5. W, In, R
6. $-\frac{4}{3}, -1.2, \sqrt{2}, 2.7, \pi$ 7. a. 7 b. Association of Addition
c. Identity of Multiplication d. False

Practice Set 2

1. a. 81 b. 81 c. -81
2. a. $\frac{14}{13}$ b. 5 c. 32
3. a. Three b. 5 c. 47
4. a. $2x^2 - x + 7$ b. $-4x + 14$ c. $14x^2 - 14$

Practice Set 3

1. a. $x = 14$ b. $n = 10$ c. $x = -\frac{7}{2}$ d. $x = \frac{5}{8}$

Practice Set 4

1. $y = \frac{7}{3}x - \frac{8}{3}$ 2. $C = \frac{5}{9}(F - 32)$

Practice Set 5

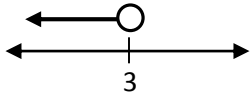
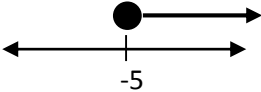
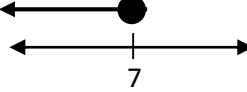
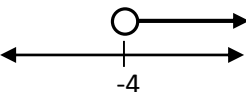
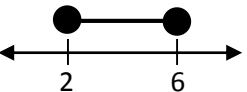
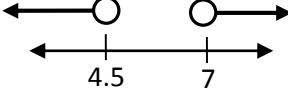
1. a.  b.  c. 
2. a. $x > -4$ b. $2 \leq x \leq 6$ c. $x < 4.5$ or $x > 7$
-   

Practice Set 6

1. $x = -2, 3$

2. $x = \frac{1}{2}, -4$

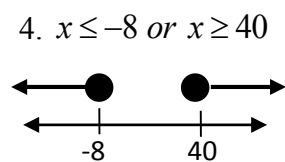
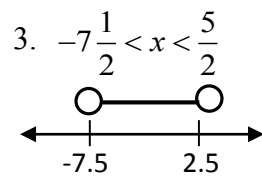

Practice Set 7

1. $m = \frac{3}{1}$

2. $m = -\frac{1}{2}$

3. $m = \frac{0}{1} = 0$

4. Undefined

5. $m = \frac{4}{-15}$

6. $m = \frac{5}{17}$

Practice Set 8

1. $m = \frac{3}{1}, b = -1$

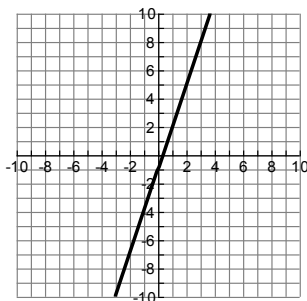

2. $m = -\frac{2}{3}, b = 2$

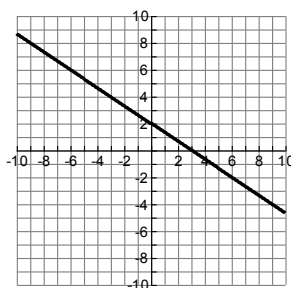

3. $x_{\text{int}} = (3, 0)$ $y_{\text{int}} = (0, -2)$

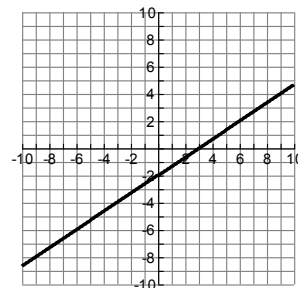

Practice Set 9

1. $y > -2x - 3$

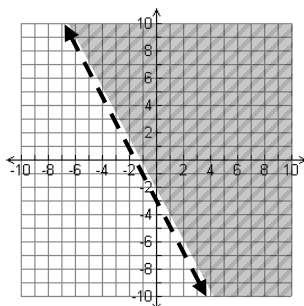

2. $y \leq 4x + 2$

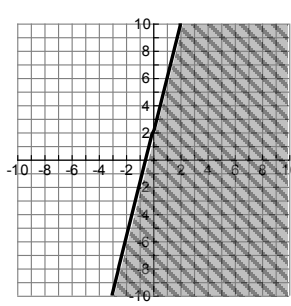

3. $y < \frac{1}{4}$

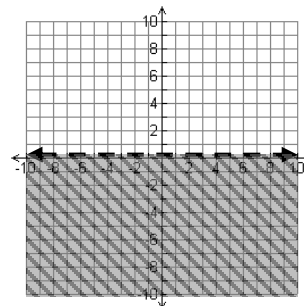

Practice Set 10

- $y = 3x - 7$
- $y = \frac{1}{2}x + \frac{5}{2}$
- $y = 4x + 22$
- $y = -4x - 1$
- $y = -\frac{3}{5}x - \frac{17}{5}$
- $y = \frac{2}{5}x - \frac{6}{5}$

Practice Set 11

- $y + 1 = 3(x - 2)$
- $y - 4 = \frac{1}{2}(x - 3)$
- $y - 12 = -14(x - 5)$ OR $y + 2 = -14(x - 6)$
- $y + 1 = -\frac{3}{5}(x + 4)$ OR $y - 2 = -\frac{3}{5}(x + 9)$

Practice Set 12

- $4x - y = 7$
- $3x + 4y = 10$
- $6x - 7y = -18$
- $7x + y = 23$

Practice Set 13

- The equation should be close to $y = .32x + 1.49$
- The equation should be close to $y = .43x + 45.29$

Practice Set 14

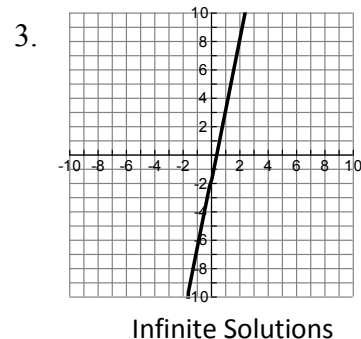
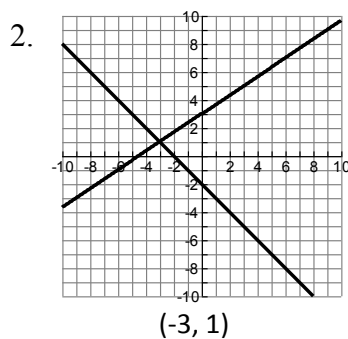
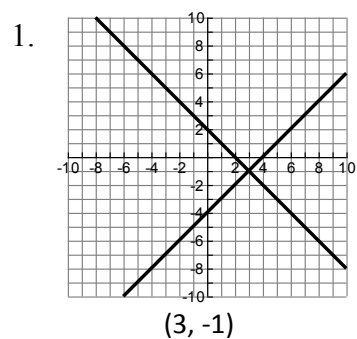

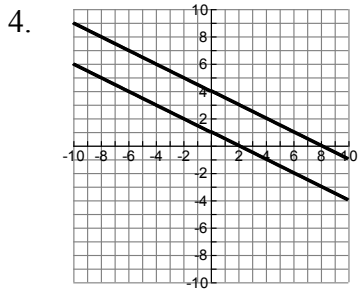

No Solution

Practice Set 15

1. (2, -1) 2. $\left(\frac{11}{2}, -16\right)$ 3. No Solution 4. Infinite Solutions

Practice Set 16

1. $\left(\frac{1}{2}, -1\right)$ 2. Infinite Solutions 3. (-4, 0) 4. No Solution

Practice Set 17

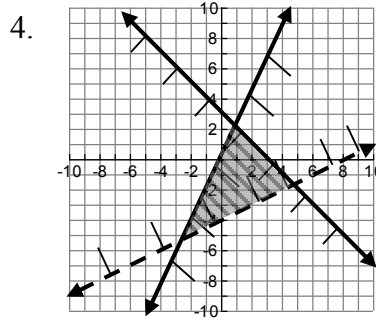
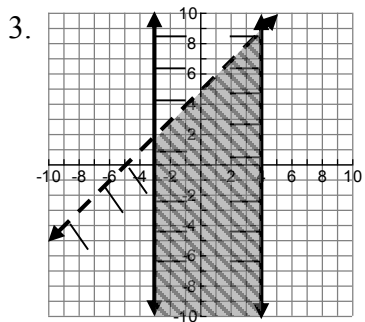
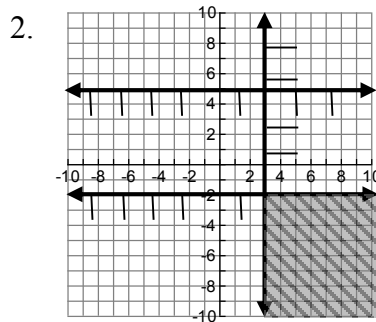
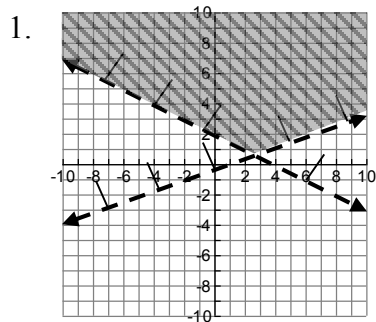

Practice Set 18

- $x + y = 84$ $x = 43$ quarters
 $.05x + .25y = 12.80$ $y = 41$ nickels
- $y = .3x + 5$ $x = 4$ rides before they are equal
 $y = .8x + 3$ $y =$ The total will be \$6.20

Practice Set 19

- $24y^5 - 8y^2 + 20y$
- $-15x^2 + 7x + 36$
- $10x^3 + 23x^2 - 11x - 15$
- $(x + 11)(x + 4)$
- $(x - 7)(x + 6)$
- $(x - 28)(x - 2)$
- $x = \frac{3}{2}, -6$
- $x = \frac{5}{4}, 2$
- $x = -\frac{5}{4}, -3$